

WARNING: Different outboard and I/O manufacturers may not use the same trim sender values. Be sure you have selected the proper trim gauge for your application.*

CAUTION: Disconnect the battery during installation. Tighten nuts on the back clamp only slightly more than you can tighten with your fingers. Six inch-pounds of torque is sufficient. Over tightening could result in damage to the instrument and may void your warranty.

1. All outboard motors and I/O's that have a trim control have a wire or terminal that provides the trim gauge signal. See your owner's manual for the location and color of this wire.
2. Be certain to use stranded, insulated wire, not lighter than 18 AWG that is approved for marine use.
3. Cut a 2-1/16" diameter hole in the dash and mount the gauge with the back clamp supplied. For connectorized cases be sure to cut a .175" wide by .115" deep notch to accept the key on the case. See detail on next page.

(See diagram on the next page for connections)

Standard Case

4. Connect a wire to the stud marked "S" (signal) and secure with a nut and lock washer. Connect the other end of the wire to the trim signal terminal or wire. It is recommended that insulated wire terminals, preferably ring type, be used on all connections to the gauge, except the light, which requires a 1/4" female blade terminal.
5. Connect a wire to the stud marked "GND" (ground) and secure with a nut and lock washer. Connect the other end of the wire to the boat's electrical ground, generally available in several locations at or near the instrument panel.
6. Connect a wire to stud marked "I" (ignition) and secure with a nut and lock washer. Connect the opposite end to a 12VDC circuit that is activated by the ignition switch.
7. Connect the blade terminal adjacent to the twist- out light assembly to the positive "+" side of the instrument lighting circuit. No separate ground is required for the lighting.

Exception: A Honda trim gauge will have an additional blade terminal for lighting circuit ground (-).

NOTE: To change light bulb, twist black socket assembly one-eighth turn counter clockwise until it pops out. Bulb pulls out of socket assembly. It is a GE No. 161 instrument lamp.

8. Reconnect the battery.

Connectorized Case

4. Insert a wire with appropriate contact to the Trim Signal function of the connector. Connect the opposite end to the trim signal wire or terminal.
5. Insert a wire with the appropriate contact to the '+' (positive) function of the connector. Connect the opposite end to a 12Vdc circuit that is activated by the ignition switch.
6. Insert a wire with appropriate contact to the ground function of the connector. Connect the opposite end to the boat's electrical ground, generally available in several locations at or near the instrument panel.
7. Insert a wire with appropriate contact to the light function of the connector. Connect the opposite end to the positive portion of the lighting circuit. Insert the connector into the back of the case.

NOTE: To change the light bulb, twist the socket assembly counterclockwise until it pops out. A 12V trim gauge requires an Oshino OL-4186NW-001972 or equivalent lamp.

Deutsch Connector

Hookup	Function
P1.1	'+' Positive
P1.2	Lights
P1.3	Trim Signal
P1.4	Ground
Connector	DT06-4S
Contact	1062-16-0122
Wedge Lock	W4S
Plug	114017

Packard Connector

Hookup	Function
P1.A	'+' Positive
P1.B	Lights
P1.C	Ground
P1.D	Trim Signal
Connector	12162189
Contact	12124075
Plug	12034413

For technical assistance, contact Faria® Marine Instruments Customer Service between 8:30 AM and 5:30 PM Eastern time weekdays at (860) 848-9271 or (800) 473-2742.

Standard Case Wire connections

HONDA TRIM ONLY

(See Exception In Text)

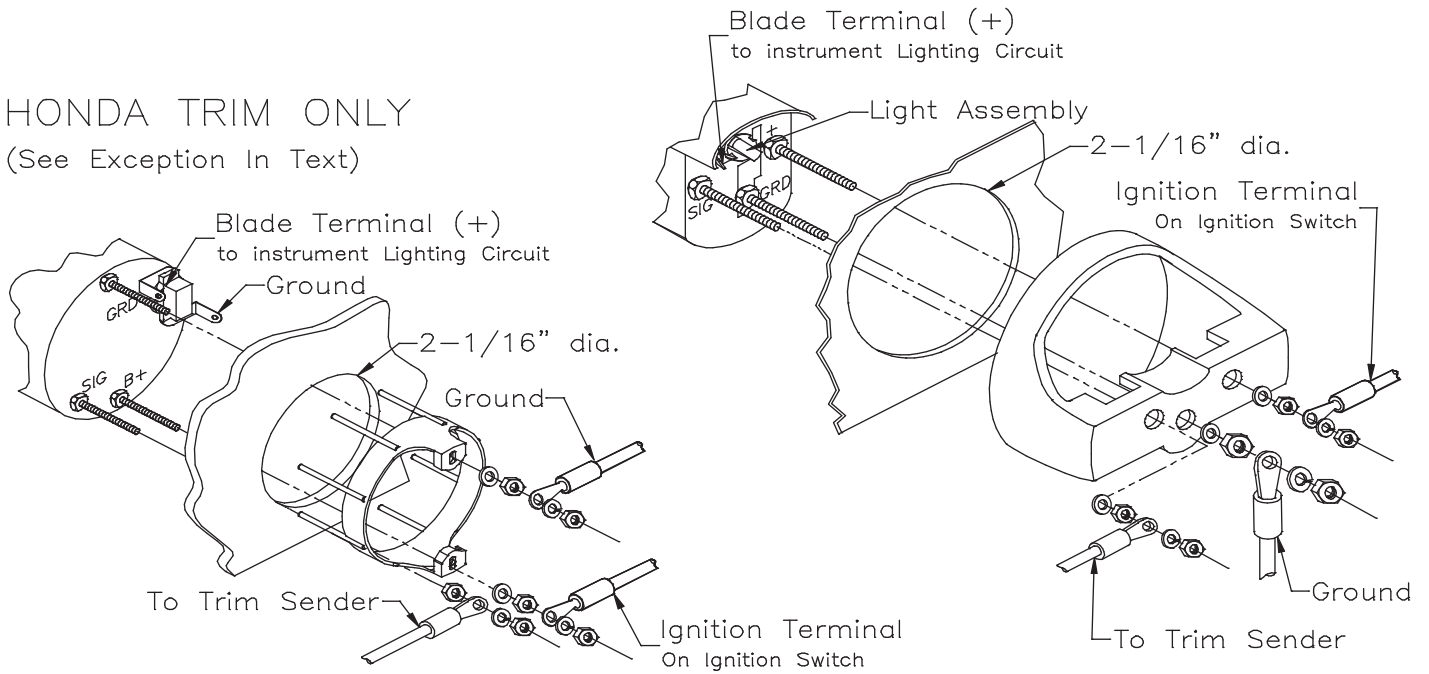

Connectorized Case Wire connections

Deutsch connector case

