

Installation and Maintenance Manual

PUMP FOR HYDRAULIC STEERING SYSTEMS

UP 20 F

UP 20 T

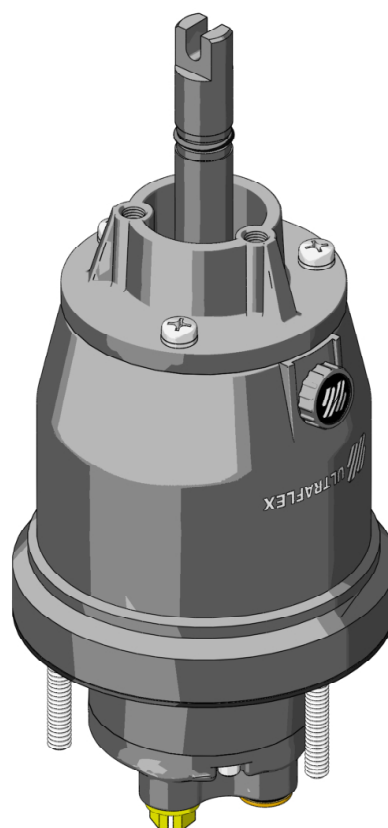
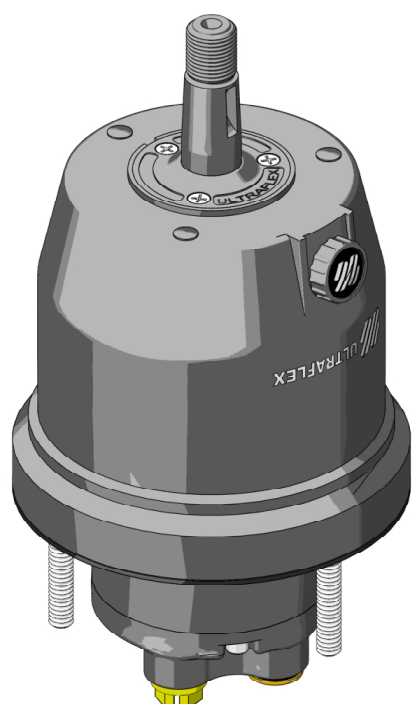

ENGLISH

ITALIANO

FRANÇAIS

CE



ULTRAFLEX

UK
page 1

I
pag. 25

F
page 49



SOCIO





Dear Customer,

We would like to thank you for choosing an **ULTRAFLEX** product.

ULTRAFLEX has been a leader in steering systems for pleasure and professional boats for many years. **ULTRAFLEX** production is since ever synonymous of reliability and safety.

All **ULTRAFLEX** products are designed and manufactured to ensure the best performance. To ensure your safety and to maintain a high quality level, **ULTRAFLEX** products are guaranteed only if they are used with original spare parts.

ULTRAFLEX and **UFLEX** Quality Management Systems are certified CISQ-IQNet by the Italian Shipping Registry (RINA), in conformity with the UNI EN ISO 9001:2008 rule. **ULTRAFLEX** certification No. 6669/02/S (former 420/96). **UFLEX** certification No. 8875/03/S.

The quality management system involves all the company resources and processes starting from the design, in order to:

- ensure product quality to the customer;
- maintain and improve the quality standards constantly;
- pursue a continuous process improvement to meet the market needs and to increase the customer satisfaction

ULTRAFLEX Environmental Management System is certified CISQ-IQNet by the Italian Shipping Registry (RINA), in conformity with the UNI EN ISO 14001 rule. **ULTRAFLEX** certification No. EMS-1282/S.

Products for pleasure boats are constantly tested to check their conformity with the 2013/53/EU.



"**ULTRAFLEX** has over 80 years of experience in the marine industry and is a world leader in the production of mechanical, hydraulic and electronic steering systems, control boxes and steering wheels for any kind of pleasure, fishing or commercial boats.

The key factors which explain the increasing success of our products all over the world are the reliability of our products and the before and after sale service, the quality of the company organization and of the human resources and the continuous spending in research and development".

TABLE OF CONTENTS



DOCUMENT REVISIONS	4
MANUAL USE AND SYMBOLS USED	5
INFORMATIVE LETTER	6
WARRANTY	6

SECTION 1 - PRODUCT DESCRIPTION

1.1 HYDRAULIC STEERING SYSTEM OPERATION	7
1.2 WARNINGS FOR THE CORRECT PRODUCT USE	7
1.3 SYSTEM CONFIGURATIONS	8
1.4 PUMP DESCRIPTION	8
1.5 PUMP TECHNICAL FEATURES	9

SECTION 2 - TRANSPORT

2.1 GENERAL WARNINGS	10
2.2 PACKAGING CONTENTS	10

SECTION 3 - INSTALLATION

3.1 TOOLS NECESSARY FOR THE INSTALLATION OF PUMP UP20 F	11
3.2 PUMP UP20 F INSTALLATION	11
3.3 TOOLS NECESSARY FOR THE INSTALLATION OF PUMP UP20 T	13
3.4 PUMP UP20 T INSTALLATION	13
3.5 TYPES OF INSTALLATION	16
3.6 HOSE CONNECTION TO THE SYSTEM	16
3.7 FILLING AND PURGING	18
3.7.1 POSITIONING OF THE OIL BOTTLE	19
3.7.2 PURGING PROCEDURE	19
3.8 GENERAL RECOMMENDATION	19

SECTION 4 - SAFETY WARNINGS

4.1 SAFETY WARNINGS DURING USE AND INSTALLATION	20
4.2 CLOTHING	20

SECTION 5 - MAINTENANCE

5.1 ORDINARY MAINTENANCE	21
5.2 STEERING WHEEL DISASSEMBLY	21
5.3 TROUBLESHOOTING	21

SECTION 6 - DISMANTLING

6.1 DISMANTLING	23
-----------------------	----









DOCUMENT REVISIONS

Rev.	Date	Revision description
0	25/09/2008	First edition
1	24/07/2013	Change of swivelling fittings
2	16/07/2014	Modification of chapters "Packaging contents" and "Positioning of the oil bottle"

MANUAL USE AND SYMBOLS USED

THE INSTALLATION AND MAINTENANCE MANUAL is the document accompanying the product from its sale to its replacement and discharge. The manual is an important part of the product itself. It is necessary to read carefully the manual, before ANY ACTIVITY involving the product, handling and unloading included.

In this manual the following symbols are used to ensure the user safety and to guarantee the correct operation of the product:

- 
DANGER

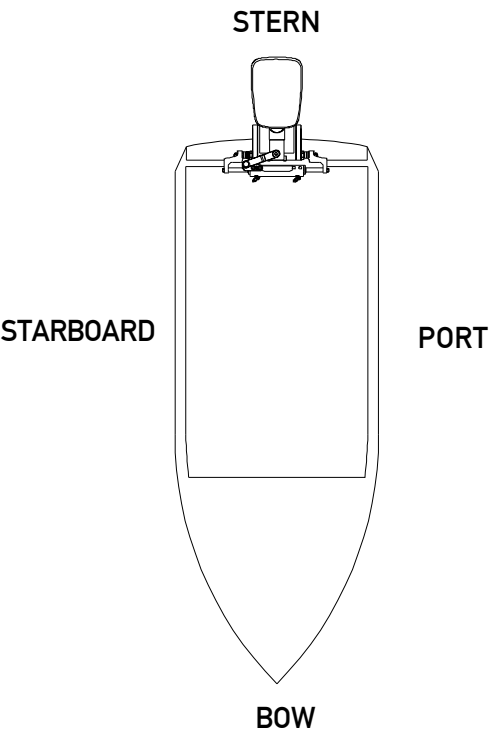
 Immediate hazards which CAUSE severe personal injury or death.
- 
WARNING

 Denotes that a hazard exists which can result in injury or death if proper precautions are not taken.
- 
CAUTION

 Denotes a reminder of safety practices or directs attention to unsafe practices which could result in personal injury or damage to the craft or components or to the environment.
- NOTICE

 Important information for the correct installation and for maintenance, that does not cause any damage.
- 

 The symbol aside indicates all the operations which must be carried out by qualified or skilled staff, in order to avoid hazards. We recommend training the staff in charge of the product installation and checking their knowledge.





The picture aside explains the meaning of some nautical words contained in this manual.

LEGEND

m.p.h. = miles per hour
 km/h = kilometres per hour

10 m.p.h. = 8,69 knots
 10 m.p.h. = 16,1 km/h
 10 knots = 11,5 m.p.h.
 10 knots = 18,5 km/h
 10 km/h = 6,21 m.p.h.
 10 km/h = 5,4 knots



INFORMATIVE LETTER

This installation and maintenance manual is an integrant part of the product and should be easily available to staff in charge of use and maintenance.

The user must know the content of this manual.

ULTRAFLEX declines all responsibility for possible mistakes in this manual due to printing errors.

Although the main features of the type of product described are not subject to change, **ULTRAFLEX** Company reserves the right to modify any parts, details and accessories it deems necessary to improve the product or for manufacturing or commercial requirements, at any time and without being obliged to update this manual immediately.

ALL RIGHTS ARE RESERVED. Publishing rights, trademarks, part numbers and photographs of **ULTRAFLEX** products contained in this manual are **ULTRAFLEX** property.

Great care has been taken in collecting and checking the documentation contained in this manual to make it as complete and comprehensible as possible. Nothing contained in this manual can be interpreted as warranty either expressed or implied - including, not in a restricted way, the suitability warranty for any special purpose. Nothing contained in this manual can be interpreted as a modification or confirmation of the terms of any purchase contract.

⚠ WARNING

To ensure the correct product and component operation, the product must be installed by qualified staff. In case of part damage or malfunction, please contact the qualified staff or our Technical Assistance Service

TECHNICAL ASSISTANCE SERVICE

UFLEX S.r.l.

Via Milite Ignoto,8A
16012 Busalla (GE)-Italia
Phone: +39.010.962.01
Fax: +39.010.962.0333
Email: ut@ultraflexgroup.it
www.ultraflexgroup.it

North - South - Central America UFLEX USA

6442 Parkland Drive
Sarasota, FL 34243
Ph: +1.941.351.2628
Fax: +1.941.360.9171
Email: uflex@uflexusa.com
www.uflexusa.com

WARRANTY

ULTRAFLEX guarantees that its products are well designed and free from manufacturing and material defects, for a period of two years from the date of manufacturing.

For the products which are installed and used on working or commercial boats the warranty is limited to one year from the date of manufacturing.

If during this period the product proves to be defective due to improper materials and/or manufacture, the manufacturer will repair or replace the defective parts free of charge.

Direct or indirect damage is not covered by this warranty. In particular the company is not responsible and this warranty will not cover the damage resulting from incorrect installation or use of the product (except for replacement or repair of defective parts according to the conditions and terms above).

This warranty does not cover the products installed on race boats or boats used in competitions.

The descriptions and illustrations contained in this manual should be used as general reference only.

For any further information please contact our Technical Assistance Service.

ULTRAFLEX steering system components are marked **CE** according to the Directive 2013/53/EU.

We remind you that only **CE** marked steering systems must be used on the boats marked **CE**.

We inform you that the **ULTRAFLEX** warranty is null if some **ULTRAFLEX** components are installed on a steering system together with products of other brands.



1 PRODUCT DESCRIPTION

1.1 Hydraulic steering system operation

All **ULTRAFLEX** hydraulic steering systems are designed in conformity with UNI-EN-ISO 10592 and A.B.Y.C. P21 regulations. All **ULTRAFLEX** steering systems can operate at temperatures between -18°C (0°F) and +77°C (+170°F). All the components are made for the marine environment, using materials and working processes which offer long life and safety under the most extreme conditions. A hydraulic steering system consists of a steering pump located on the dashboard, a cylinder tied to the rudder or to the outboard or sterndrive engine and the connecting hoses (see picture). Under normal operating conditions, a turn of the steering wheel will pump the oil, which flows in through the hoses to the cylinder, according to the turn direction. With the consequent cylinder movement the oil will flow to the pump through the hoses and at the same time moves the engine or the helm which are connected to the cylinder. The pumps equipped with a nonreturn valve, which prevents outgoing fluid from returning along the same hose, allow the operation of the steering systems with two or more steering stations. The cylinders are double-acting and they can be balanced or unbalanced. In unbalanced cylinders the two chambers have different volumes and therefore they require a different number of steering wheel turns and a different steering wheel rotation effort with the same movement in the two directions. The balanced cylinders require the same number of turns of the steering wheel to move the helm from the centre to the end of stroke in the two opposed directions.

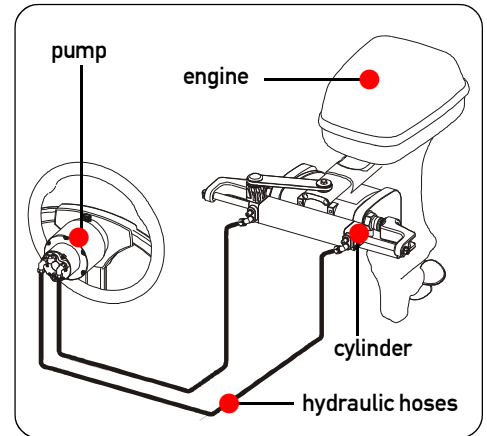

A well balanced steering system needs a correct choice of the pump for the cylinder. **ULTRAFLEX** produces different pump models, which have different capacity (cm³ of oil moved each steering wheel turn) and for each type of installation. While choosing the pump it is important to consider the cylinder volume. The number of starboard and port turns is determined by the ratio between the cylinder volume and the pump capacity.

Example: if the pump has a capacity of 28 cm³ [1.7cu.in.] and the cylinder has a volume of 120 cm³ [7.3cu.in.], the formula looks like this: $120/28=4.2$. Accordingly, the steering wheel will turn about 4 times before the cylinder will completely turn from one side to the other. In case of installations with double cylinders connected in parallel the cylinder volume must be added. Applications with less than 4 turns are not recommended, as they need a higher effort, also applications with more than 8 turns are not recommended, as the response of the boat to steer is slowly.

1.2 Warnings for the correct product use

⚠ DANGER

Do not modify the pump in any way to fit it to your application, otherwise the pump will no longer operate in safety and it will endanger the boat and the occupants.

⚠ WARNING

All **ULTRAFLEX** steering systems must not be installed on boats equipped with engines whose maximum horsepower is higher than the horsepower rating approved by boat manufacturer.

⚠ WARNING

ULTRAFLEX steering systems must not be installed on race boats.



1.3 System configurations

The pump UP20 can be installed in a single or double steering system and used with different types of configurations of front, side or inboard cylinders.

⚠ WARNING

The pump model UP20 can be installed only on boats with single engine, whose horsepower is lower than or equal to 150 hp and whose maximum speed does not exceed 35 m.p.h.

⚠ WARNING

Always connect the hoses correctly as indicated in the installation and maintenance manuals of the corresponding hydraulic cylinders.

1.4 Pump description

The pumps UP20 F and UP20 T have been designed and manufactured to be used as a component in the hydraulic steering systems, as described in the previous paragraph. The pump UP20 F must be installed on the front part of the boat dashboard or semi-built-in through flange X64; the pump UP20 T must be assembled by means of tilt X52 (supplied separately). The following pictures show the main pump components:

- | | |
|-----------------------------------|--|
| 1 Pump UP20 F | 5 Connections to the additional stations |
| 2 Vented tank plug | 6 M8 dowels for fixing the pump to the dashboard |
| 3 Steering wheel connection shaft | 7 Pump UP20 T |
| 4 Connections to the cylinder | 8 Connection shaft to tilt X52 |

UP20 F

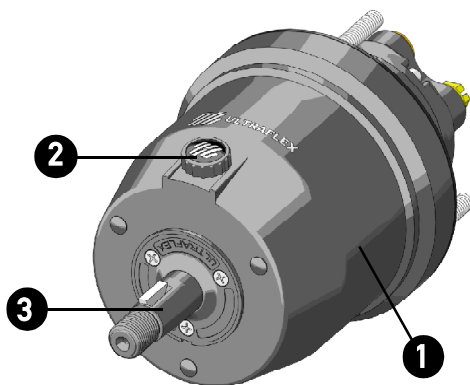

UP20 T

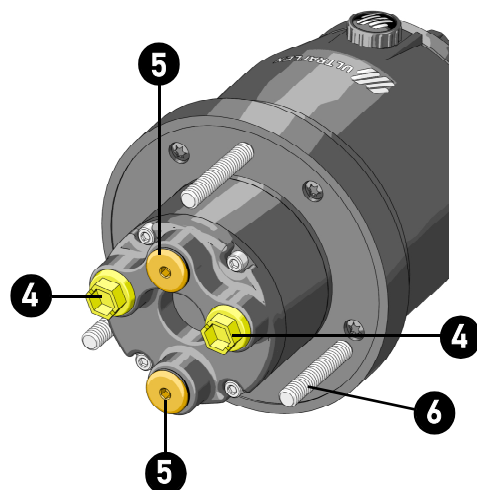
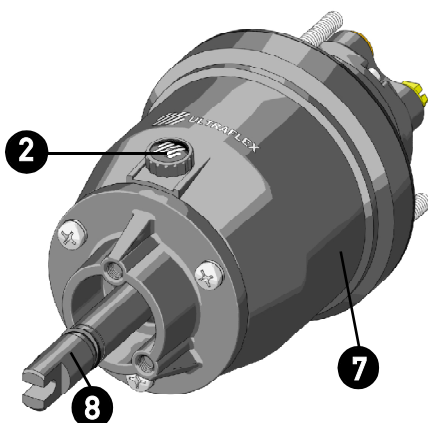

1.5 Pump technical features

SPECIFICATIONS	PUMP UP20 F	PUMP UP20 T
Capacity	20 cc/rev. - 1,2 cu.in/rev.	20 cc/rev. - 1,2 cu.in/rev.
Pressure relief valve release pressure	70 bar (1000 psi)	70 bar (1000 psi)
No. of pistons	5	5
Max. steering wheel diameter	508 mm (20 in.)	406 mm (16 in.)
Max. steering wheel dish	115 mm (4,5 in.)	127 mm (5 in.)
Weight	3,6 kg (8 lbs)	3,9 kg (8,5 lbs)
Oil	See table paragraph "filling and purging"	See table paragraph "filling and purging"

⚠ CAUTION

The release pressure of the pressure relief valves does not correspond to the system normal pressure but it represents only the use limits.

ENGLISH

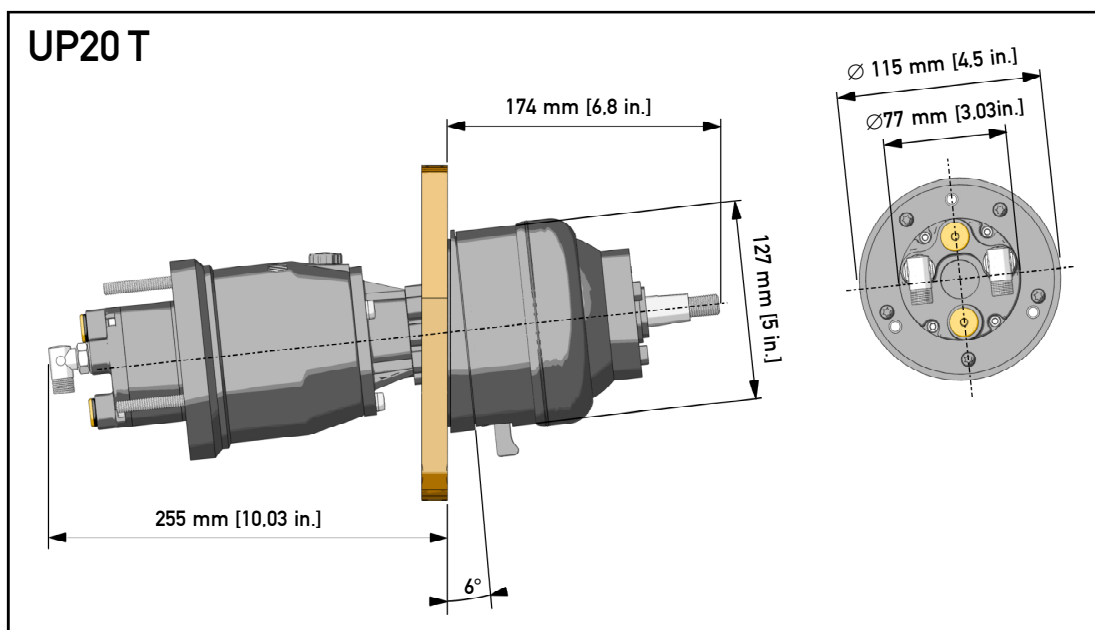
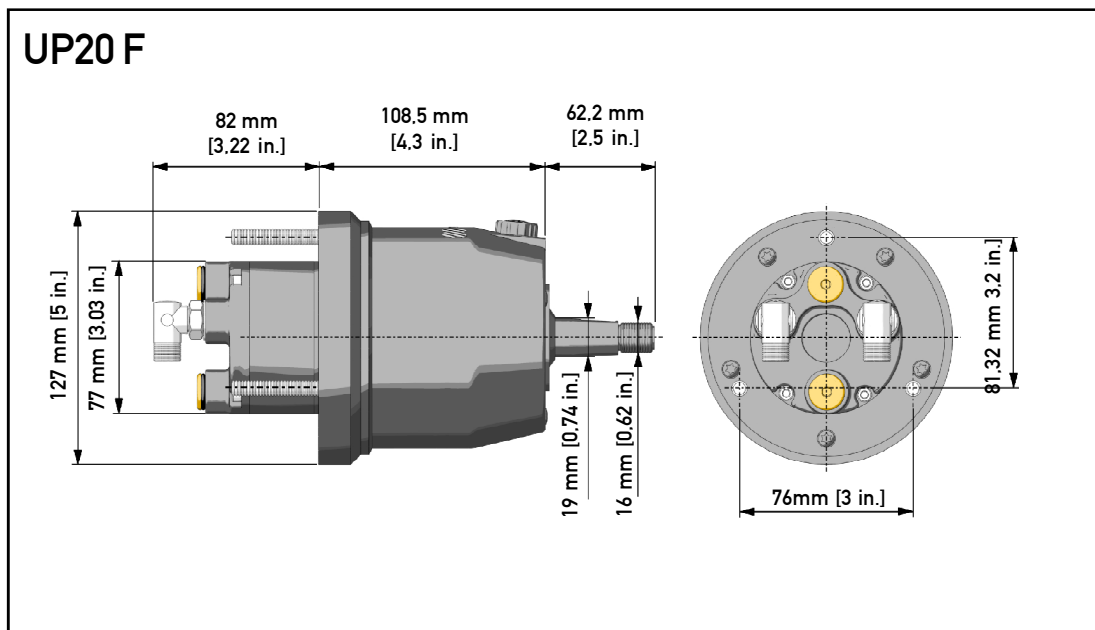

⚠ CAUTION

The pump UP20 T must be assembled only by means of tilt X52 (supplied separately).



2 TRANSPORT

2.1 General warnings

The pump UP20 F weight with its packaging is 4,5kg (9.92 pounds); the pump UP20 T weight with its packaging is 4.8 kg (10.58 pounds) and so they can be handled manually.

⚠ WARNING

The staff in charge of handling must operate with protective gloves and safety shoes.

2.2 Packaging contents

Before using the equipment check that the product has not been damaged during transport. Also make sure that all the standard components are in the packaging (see list). In case of damage, notify the claim to the forwarder and inform the supplier.

The packages contain:

A) pump UP20 F with seals for dashboard fixing;

B) pump UP20 T;

C) for pump UP20 F: 2 90° swivelling fittings to connect the Kit OB pipes (supplied separately); 3 nuts and 3 washers for fixing the pump to the dashboard; 1 nut, 1 washer, 1 key for steering wheel tightening; 1 label for plug;

D) for pump UP20 T: 2 90° swivelling fittings to connect the Kit OB pipes (supplied separately); 1 label for plug.

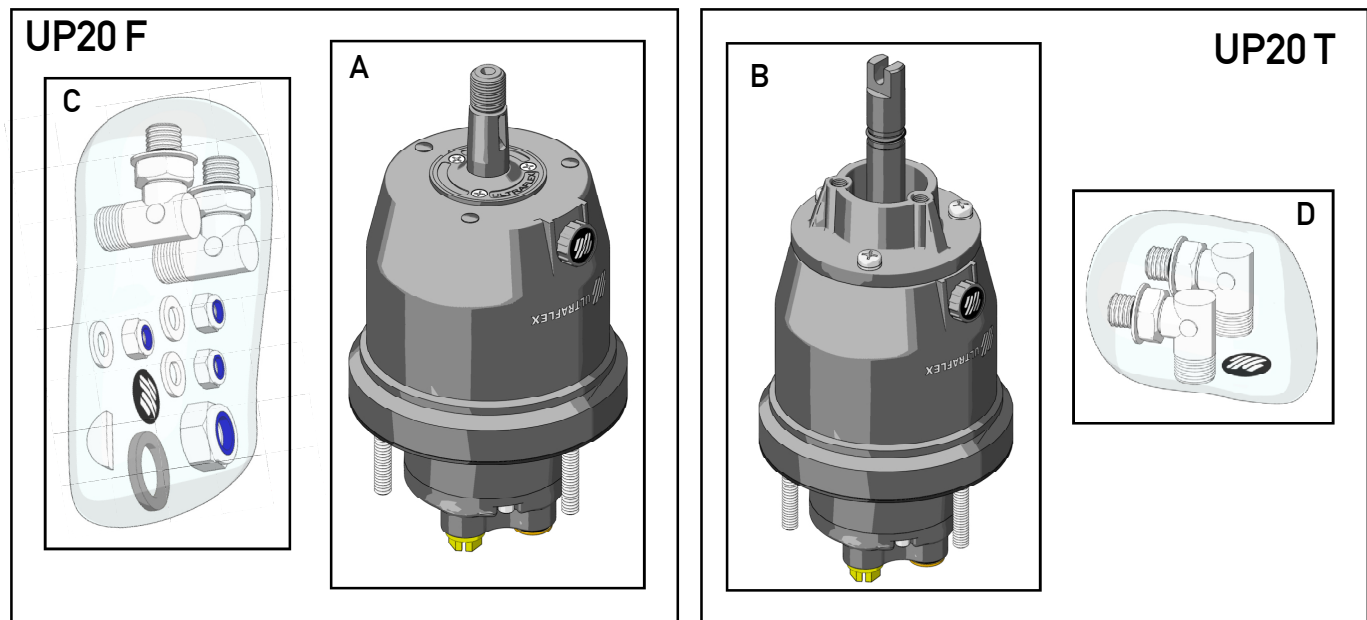

⚠ CAUTION

The packaging must be disposed of according to the existing laws.



3 INSTALLATION

3.1 Tools necessary for the installation of pump UP20F



MOLYKOTE® 1000



Torque wrench



Drill



Open end wrench
13 mm



Open end wrench
11/16"



Screwdriver

3.2 Pump UP20 F installation



1 Select a suitable place for the steering station. Make sure that there is enough manoeuvring space for the steering wheel and for the steering pump and its pipes and fittings.

⚠ WARNING

In order to fix the pump properly, the maximum dashboard thickness must be 30 mm [1.18 in.]. Different thicknesses could compromise the driving safety. Make sure that the breaking ring of the 3 self-locking nuts supplied is engaged by the dowel thread.

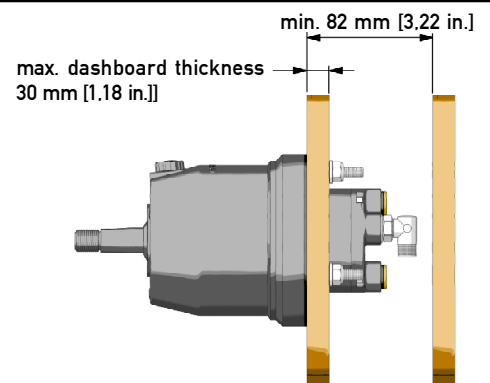

2 Remove the plugs (1) from the pump (2) by using a screwdriver.

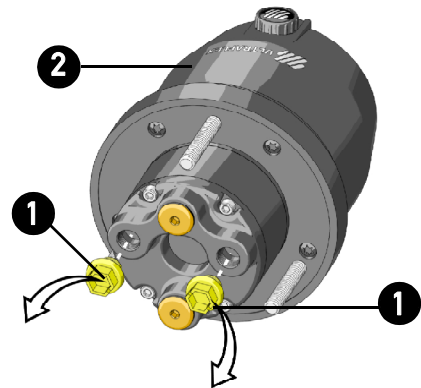

3 Screw the nuts completely on the corresponding 90° unions (3). Fit and screw the unions manually as indicated in the picture until they are inserted completely. Turn them until they are positioned correctly with respect to the pipes by unscrewing them no more than one revolution, then tighten the nuts with a 11/16" Allen wrench with a torque of 17,6 Nm (13 lb ft) until the washer touches the nut.

⚠ WARNING

DO NOT USE teflon tape or adhesive tape.
DO NOT PUT any thread sealant like Loctite 542 or similar products.

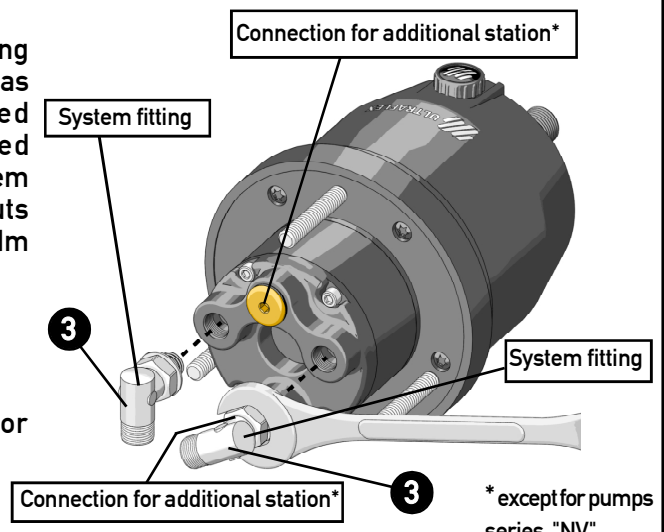

* except for pumps series "NV"



4 By using the proper template supplied with this manual, make the 3 holes (4) for M8 dowels and the central hole.

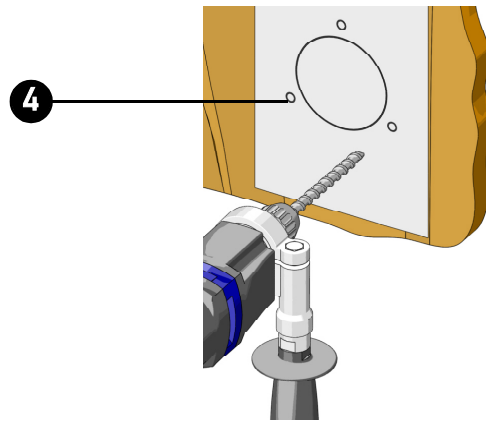

5 Position the pump (2) on the dashboard front side (5) interposing the gasket (6) and fix it by inserting the 3 washers (7) and by tightening the 3 self-locking nuts (8) with a 13 mm wrench and a torque of 12 Nm (8.85 lb_fft).

⚠ CAUTION

If the self-locking nuts are disassembled (8), they must be replaced. (Contact our assistance service, see page 6).

⚠ WARNING

Install the pump by positioning the filling hole (9) towards the top (see the picture) for the right pump operation and to allow filling and purging the system completely (see par. 3.7).

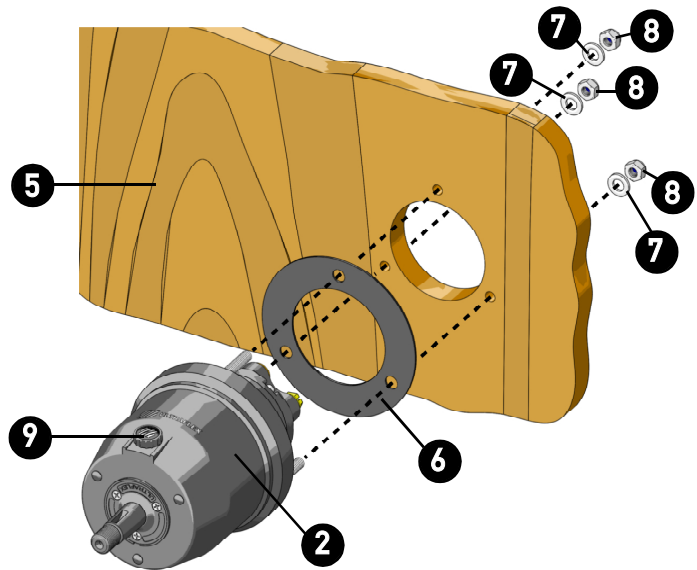

6 Position the steering wheel supplied separately (10) on the pump shaft (11) by using the suitable key (12). Insert the washer (13) and tighten the self-locking nut (14) with a 15/16" open end wrench and with a torque of 30 Nm (22.14 lb_fft); then grease the thread by using some anti-seize grease MOLYKOTE® 1000 or a similar one.

⚠ CAUTION

If the self-locking nut (14) is disassembled, it must be replaced. (Contact our assistance service, see page 6).

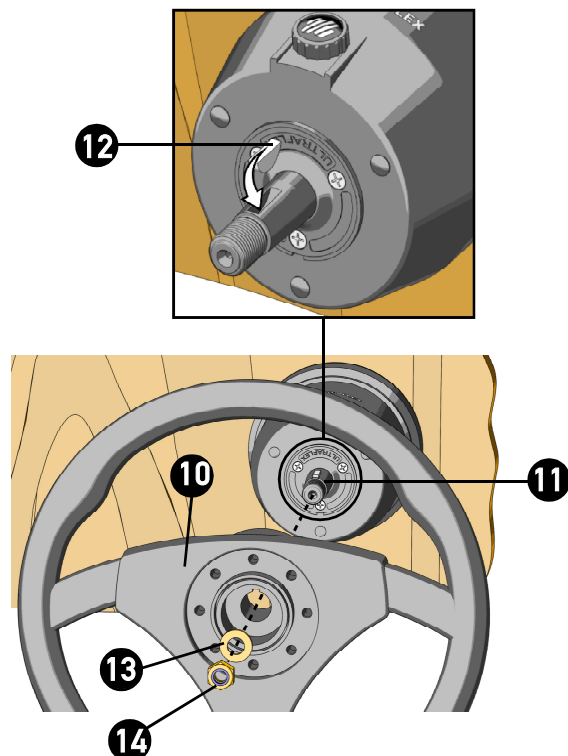

3.3 Tools necessary for the installation of pump UP20T



Open end
wrench
13 mm



Screwdriver

* The tools to assemble tilt X52 are listed in the manual enclosed to tilt X52.

3.4 Pump UP20 T installation



NOTICE

The tilt X52 mechanism is supplied separately.

1 Select a suitable place for the steering station. Make sure that there is enough manoeuvring space for the steering wheel and for the steering pump and its pipes and fittings.

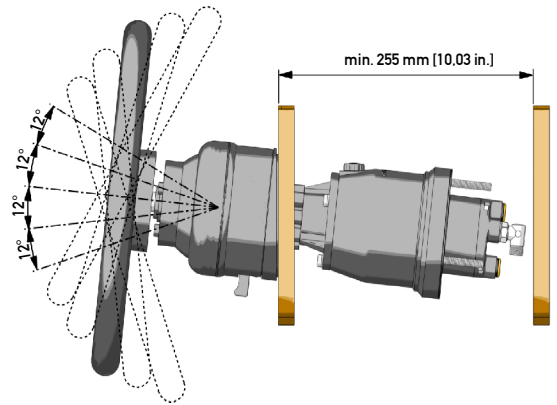

2 Remove the plugs (1) from the pump (2) by using a screwdriver.

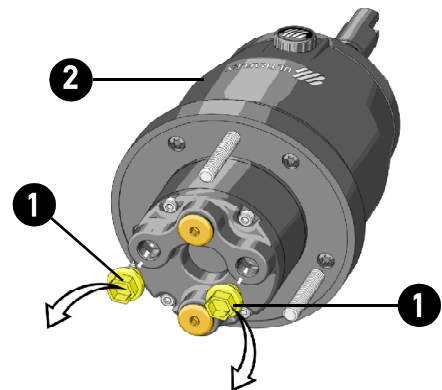

3 Fix the bracket (3) supplied with tilt X52 to the dashboard (4) by following the instructions enclosed to tilt X52.

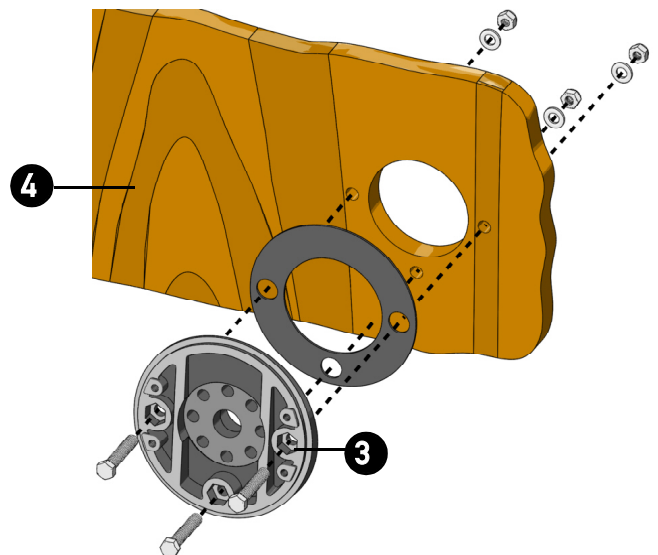

4 Screw the nuts completely on the corresponding 90° unions (3). Fit and screw the unions manually as indicated in the picture until they are inserted completely. Turn them until they are positioned correctly with respect to the pipes by unscrewing them no more than one revolution, then tighten the nuts with a 11/16" Allen wrench with a torque of 17.6 Nm (13 lb ft) until the washer touches the nut.

⚠ WARNING

DO NOT USE teflon tape or adhesive tape.
DO NOT PUT any thread sealant like Loctite 542 or similar products.

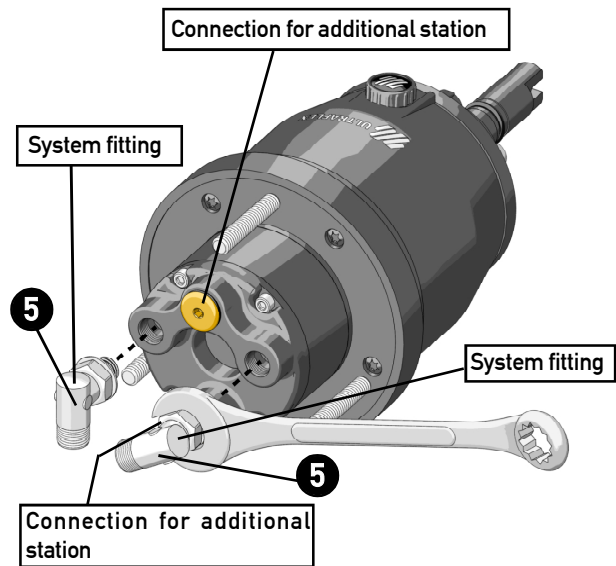

5 Fix the pump to the bracket (3) supplied with tilt X52 by using the 3 M8 screws (6) supplied with tilt X52 according to the instructions enclosed to tilt X52.

⚠ WARNING

Install the pump by positioning the filling hole (7) towards the top (see the picture) for the right pump operation and to allow filling and purging the system completely (see par. 3.7).

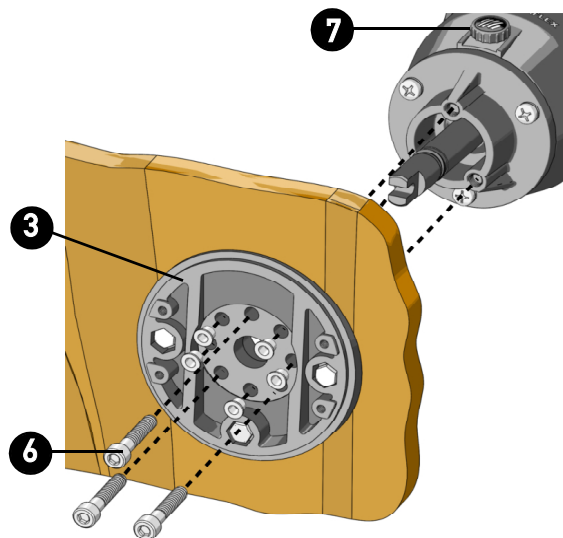

- 6 Align and insert the tilt universal joint into the pump shaft by loosening about 1-1.5 turns the screws (8) on the universal joint itself always according to the procedure described in the installation manual supplied with tilt X52. Retighten the screws (8) and fix the tilt.

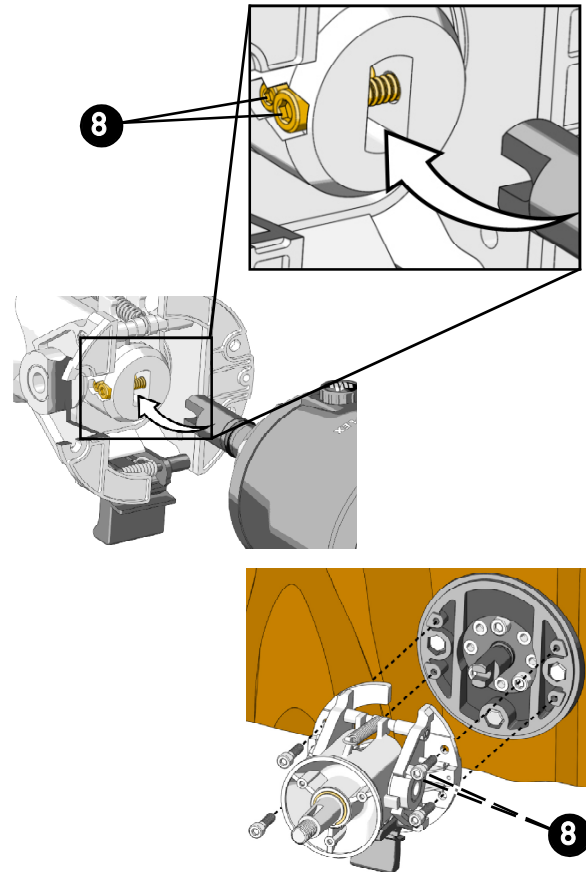
**NOTICE**

The kit F **ULTRAFLEX** supplied separately (see the corresponding instructions) can be used on pump UP20 T to simplify the hydraulic system filling and purging.



3.5 Types of installation



The pump model UP20 can be installed in a single or dual station and they can be used with different types of front mount, side or inboard cylinder configurations.

⚠ WARNING

The pump model UP20 can be installed only on boats with single engine, whose horsepower is lower than or equal to 150 hp and whose maximum speed does not exceed 35 m.p.h.

NOTICE

If the system is used with a UC94 cylinder, speed can reach 55 m.p.h. (48 knots), always with maximum power of 150 hp.

⚠ WARNING

Connect hoses as shown in the installation and maintenance manual of the corresponding hydraulic cylinders.

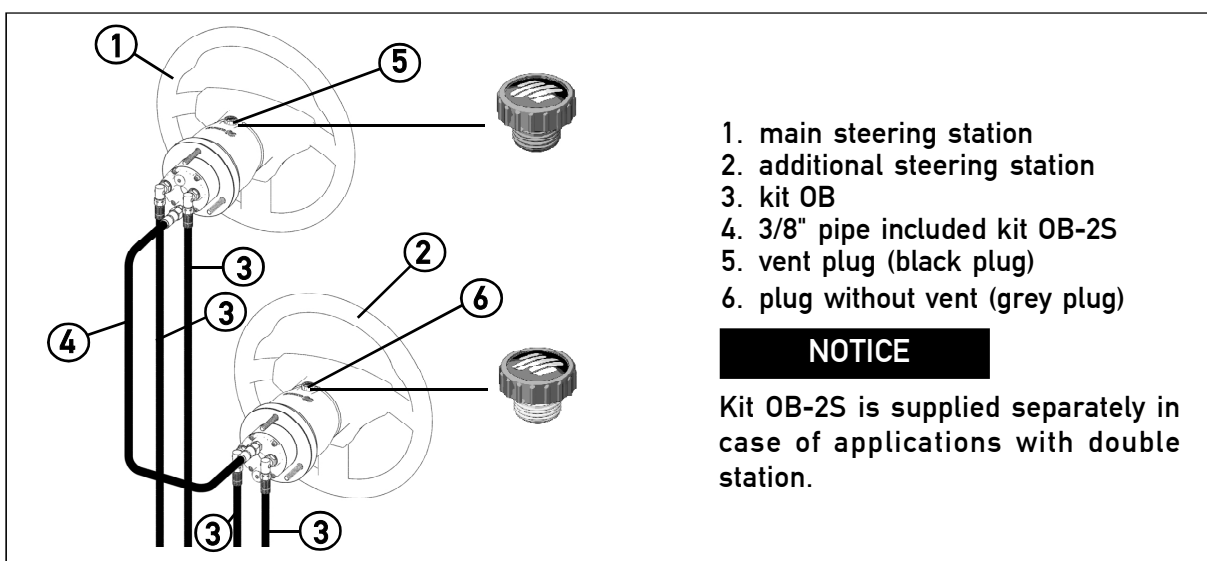

1. main steering station
2. additional steering station
3. kit OB
4. 3/8" pipe included kit OB-2S
5. vent plug (black plug)
6. plug without vent (grey plug)

NOTICE

Kit OB-2S is supplied separately in case of applications with double station.

⚠ CAUTION

The main steering station is the only one which is equipped with vent plug and it is always the one placed in the higher position. The additional steering station or possible other stations must be placed below the main steering station and equipped with plug without vent.

3.6 Hose connection to the system



- 1 Connect the hydraulic hoses **ULTRAFLEX** kit OB (supplied separately) joining the pump and the cylinder by following the instructions given in the installation manual of the kit OB.
- 2 If one or more additional steering stations are installed, use the kit OB-2S by following the suitable instructions.

Put straight fittings (included in the OB-2S kit) (1) on the pumps as shown in picture. Put some Loctite 542 or Loctite 545 sealant on the fitting thread. Fit and screw fittings (1) manually until they are completely inserted, then tighten them with a 7/16" hexagonal wrench with a torque of 17,6 Nm (13.0 lb_fft).

⚠ WARNING

Do not use teflon tape or any other adhesive tape. Please, pay great attention when putting the sealant, since it could jam the system preventing its proper operation after reaching it.



MAIN STEERING STATION

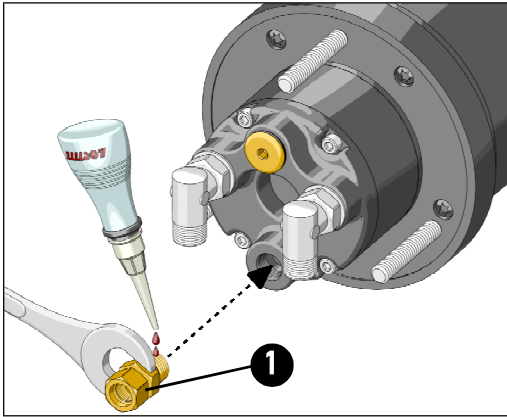

ADDITIONAL STEERING STATION

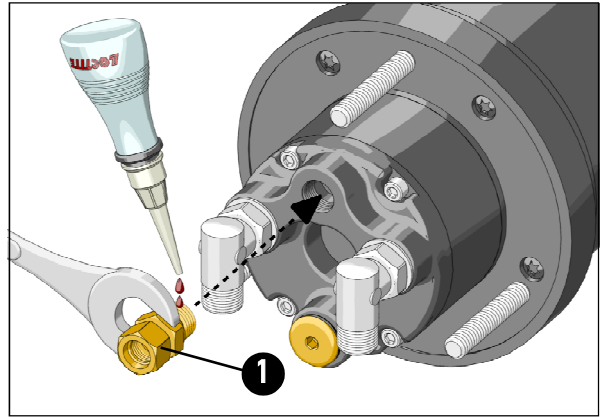

3 Connect pipes as shown in picture following the manual instructions.

MAIN STEERING STATION

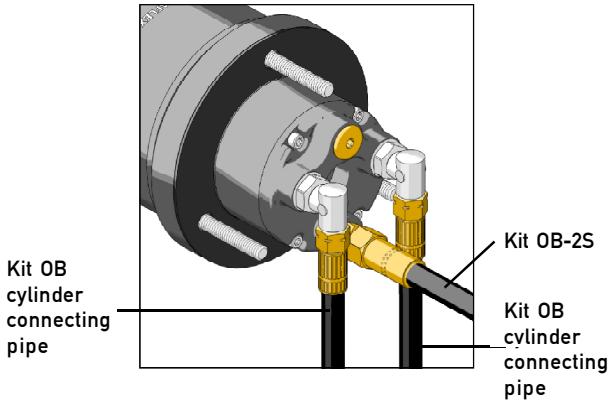

ADDITIONAL STEERING STATION

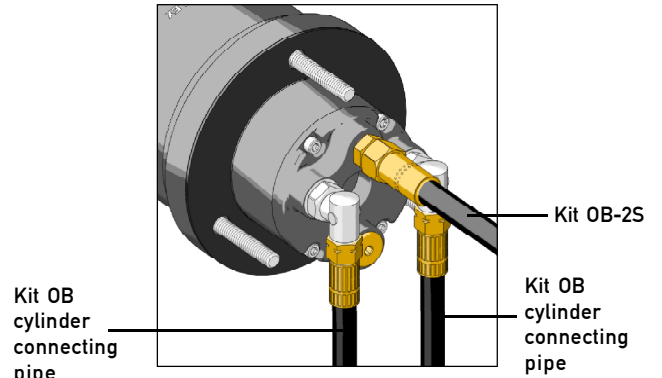

⚠ WARNING

Keep the pipes far from heat sources and from chemical substances. Protect the pipes that must pass through bulkheads by using suitable thru hulls. The bends must be perfectly smooth; any bent pipe or dent would prevent the hydraulic oil passage.

⚠ WARNING

Keep clean. Make sure that working areas are free from dust and dirt. The protective plugs of threaded holes must be removed only before the connection of fittings and pipes. Make sure that pipes are perfectly clean and free from swarf. If copper or steel pipes are used, cleaning is mandatory. If the installer uses pipes that are different from Kit OB, he must take full responsibility for it.

⚠ WARNING

At the end of the installation make sure that the pipes do not interfere with the engine and with fixed or mobile parts of the boat or of the steering system itself.

⚠ WARNING

The minimum bending radius of the pipes is 250 mm. Any excessive pipe bending could break them by compromising the good operation of the system. If necessary, replace the damaged pipe.

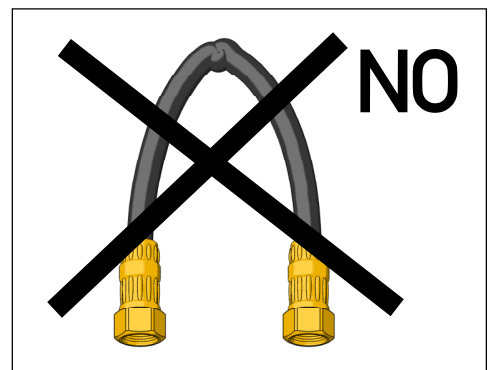
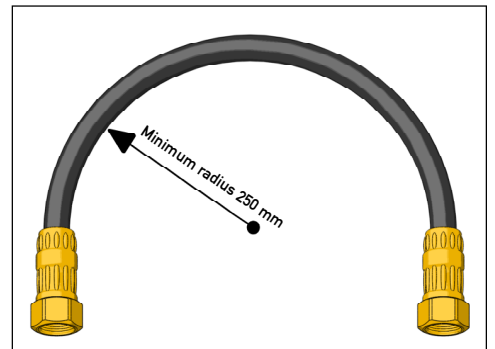



3.7 Filling and purging

After the first installation and after maintenance operations it is necessary to fill the system with hydraulic oil. This operation must avoid the air in the system, to ensure the good system operation. The hydraulic system must be filled from the highest point of the system, which means from the upper steering station.

⚠ CAUTION

To avoid air bubbles in the oil, it is necessary to fill the tank slowly.

⚠ WARNING

The filling and bleeding operations must be carried out at least by two operators

NOTICE

The filling and purging operations can be facilitated by using the automatic purging equipment BUBBLE BLUSTER® (supplied separately).

⚠ DANGER

Use **ULTRAFLEX** oil or other compatible oils.

Hydraulic oil OL150 has been specifically formulated for **ULTRAFLEX** to ensure high quality performance level of **ULTRAFLEX** products throughout time.

Its special "Zinc Free" formula enhances protection against marine oxidation. The special mix of anti-wear and stabilizing components of OL150 allow ensuring great results as far as the product duration and performances are concerned in several environmental conditions. **ULTRAFLEX** hydraulic oil complies with standard ISO 10592 concerning hydraulic steering systems. **ULTRAFLEX** is not to be held responsible for any damages or performance deterioration if oils different from OL150 are used.

⚠ DANGER

Do NOT use ATF Dexron II transmission oils or brake oils which could cause the steering system seizing.

Oils which are compatible with OL150 **ULTRAFLEX** are:

- Shell Tellus T15 and Shell Tellus T22
- Mobil DTE 11M

NOTICE

ULTRAFLEX will not be able to ensure the compatibility of the above mentioned oils with OL150 if the oil manufacturers vary their formulation; in particular, it will not be able to ensure its compliance with standard ISO 10592 concerning hydraulic steering systems. Under no circumstances **ULTRAFLEX** is to be held responsible for any damages or performance deterioration.

In the days after the filling, check the oil level; if necessary top off the system.

At the beginning the oil level can lower, as small amounts of air can be released in a homogeneous way. According to the types of installation, it is necessary to carry out the different bleeding procedures, as it follows.



3.7.1 Positioning of the oil bottle

To carry out this operation, it is necessary to use the oil filling kit (1 needle, 1 transparent pipe, 1 pipe connection and 1 spout for the oil bottle). This kit is NOT supplied.

- Remove the pump cap and insert the fittings.
- Attach the spout to a new bottle of hydraulic oil and connect the hose to the fittings and the bottle spout.
- Turn the bottle upside down and pierce it with the pin, as shown in the picture, to ease the oil passage towards the pump.

Fill the pump until no air bubbles are visible in the hose.

⚠ WARNING

While replacing the oil bottle, during the filling process, close all the bleed valves of the cylinder/s. To bleed the system, check that oil is always present in the filling hose. If some air is in the system during the bleeding process, the whole bleeding process must be started again.

⚠ CAUTION

Replace the bottle before it empties and use recovered oil only after 24 hours.

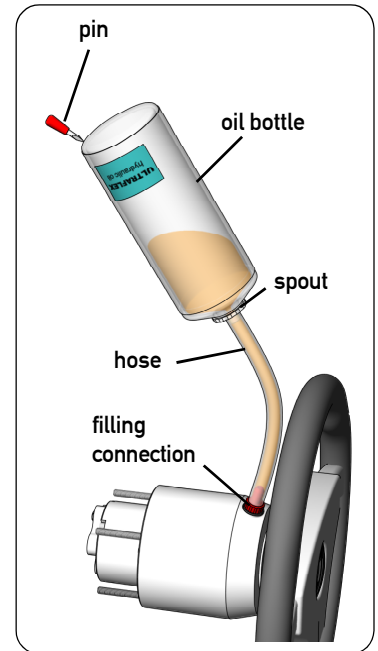

3.7.2 Purging procedure

NOTICE

Carry out the purging procedure as indicated in the installation and maintenance manual of the cylinder used. Then check that the oil level is suitable by turning 1/2 turn the steering wheel and by making the oil come out of the bleed valve. Close the valve and check the system.

3.8 General recommendation

⚠ WARNING

It is very important to check the absence of air in the system before using the boat! We recommend trying to manually move the engine/s or the helm/s towards port and starboard, making sure that there is no movement of the cylinder body on the main cylinder shaft.

If the cylinder body moves too much, there is still air in the system. The air presence in the system can cause bad responses to the controls and so it can cause damage, injuries or death.

⚠ WARNING

Check the system response by moving the pump.

⚠ DANGER

After 24 hours repeat the purging and make sure there are no leaks.



4 SAFETY WARNINGS

This section shows the safety rules which must be followed for the correct equipment operation. We recommend reading carefully this section and also the other manuals supplied with the steering system components.

4.1 Safety warnings during use and installation

RESPECT STRICTLY the following safety rules.

ULTRAFLEX declines all responsibility in case the user does not follow these rules and it is not responsible for negligence during the use of the system.

DANGER

- **DO NOT PUT HANDS BETWEEN THE MOVING PARTS.**
- Do not disable the safety devices.
- Do not modify or add devices to the system, without **ULTRAFLEX** written authorisation or technical intervention which will prove the modification.
- Do not use the equipment for a purpose different from the one it has been designed for, which is specified in the installation and maintenance manual.
- Do not let non-specialized staff perform the installation.
- Do not disassemble the hydraulic connections before bleeding the oil in the system completely. The hoses can contain high pressure oil.
- In case of installation with double station DO NOT use both stations. As a matter of fact the two stations are always enabled on the steering compartment. The effect of the rudden rotation on both stations will double causing an undesired manoeuvre.

WARNING

- Do not put the feet on the cylinder.
- Check the system after the installation and the purging but before operating the vessel. Turn the steering wheel until the cylinder/s reaches/reach the end stroke.
Turn the steering wheel to the opposite direction. Repeat on each installed helm to verify the correct installation and the system operation.
- Carefully use sealing fluid (such as Loctite). If it reaches the hydraulic system, it may cause damage and mechanical failure.
- Do not use teflon tape or adhesive tape to seal the fittings, as this material may be injected, by causing the system fail.
- During the system installation, prevent foreign matters from entering the system. Even a little object may cause lasting damage that are not detected immediately.
- Avoid too narrow bend radius of hoses.
- Avoid the hose contact with edges or sharp corners.
- Avoid the hose contact with heat sources.

4.2 Clothing

WARNING

During installation, inspection or maintenance, IT IS STRICTLY FORBIDDEN to wear necklaces, bracelets or clothes which could get caught in the moving parts.

5 MAINTENANCE

5.1 Ordinary maintenance

⚠ WARNING

Poor installation and maintenance may result in loss of steering and cause property damage and/or personal injury. Maintenance requirements change according to climate, frequency and the use. Inspections are necessary at least every year and must be carried out by specialized marine mechanics. Check the cylinder fittings and the seals and the helm gaskets to prevent leaks. Replace them if necessary.

To keep a suitable oil level in the tank, fill and bleed the system as described in this manual in paragraph 3.9 and in the bleeding procedure of **ULTRAFLEX** cylinders. Check the hose and the entire system wear, the nut and bolt tightening every six months and make sure that they are not damaged. Clean the system using water and non-abrasive soap. .

⚠ DANGER

Use only compatible hydraulic oils, indicated in the paragraph "technical features" and "filling and purging". Do not use brake oils or automatic transmission fluid (ATF) in any case.

5.2 Steering wheel disassembly

To remove the steering wheel from the pump shaft, use a suitable extractor.

⚠ WARNING

Do not use a hammer or other tools that could seriously damage the pump.

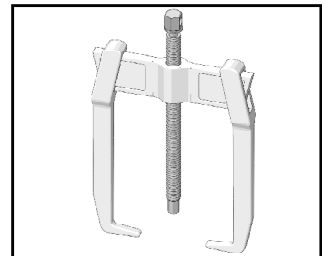

5.3 Troubleshooting

⚠ WARNING

Whenever the following checks need the removal and/or disassembly of the steering system components, such work must be carried by specialized staff. **ULTRAFLEX** offers general information only and is not responsible for any consequences resulting from incorrect disassembly.

PROBLEM	CAUSE	SOLUTION
During the filling, the steering system becomes completely jammed.	<ul style="list-style-type: none"> Blockage in the hoses between steering system and cylinder. 	<ul style="list-style-type: none"> Replace hoses. <p>⚠ DANGER The damaged hose must be replaced, otherwise it may cause loss of steering and severe personal injury or property damage.</p>
The system is very difficult to fill. Air keeps bubbling at the top of the steering system tank even after filling the system completely.	<ul style="list-style-type: none"> Air in the system. 	<ul style="list-style-type: none"> Repeat the filling and the bleeding procedure of the system. Install horizontally the hoses and in any case with a maximum inclination of 3cm each meter.
	<ul style="list-style-type: none"> Leaks from the cylinder bleeder. 	<ul style="list-style-type: none"> Tighten the bleeder on the cylinder.
	<ul style="list-style-type: none"> Coiled hose. 	<ul style="list-style-type: none"> Uncoil and straighten the hose.
	<ul style="list-style-type: none"> Helm has been mounted upside down. 	<ul style="list-style-type: none"> Mount the helm with the filling hole in up position.



The steering system is stiff and hard to turn, even when the boat is not moving.	<ul style="list-style-type: none"> Restrictions in hoses or fittings. 	<ul style="list-style-type: none"> Look for and remove the restriction.
	<ul style="list-style-type: none"> Air in oil. 	<ul style="list-style-type: none"> Repeat the filling and the bleeding procedure of the system.
	<ul style="list-style-type: none"> Wrong oil has been used. 	<ul style="list-style-type: none"> Drain the filling and bleeding system. <p>⚠ WARNING</p> <p>ULTRAFLEX is not responsible for damage caused by fluids that are not recommended in this manual and so the warranty is cancelled.</p>
The steering system is stiff and hard to turn, even when the boat is not moving, if unbalanced cylinders are used.	<ul style="list-style-type: none"> Dirt in the valve. 	<p>⚠ WARNING</p> <p>Do not use the boat and contact a specialized technician for the valve cleaning.</p>
The steering system is easy to turn at the dock but becomes hard to turn when the boat is in motion.	<ul style="list-style-type: none"> The steering wheel is too small. 	<ul style="list-style-type: none"> Replace the steering wheel with a bigger one. <p>⚠ WARNING</p> <ul style="list-style-type: none"> Only within the maximum dimensions allowed by the helm.
	<ul style="list-style-type: none"> Incorrect setting of the torque tab. 	<ul style="list-style-type: none"> Adjust the torque tab.
	<ul style="list-style-type: none"> Air in oil. 	<ul style="list-style-type: none"> Check the oil level and repeat the bleeding procedure as explained in this manual.
When the steering wheel is turned, the rod (movable rod cylinders) or the body (fixed cylinder rod) of the cylinder do not move.	<ul style="list-style-type: none"> Air in the system. 	<ul style="list-style-type: none"> Repeat the filling and bleeding procedure of the system.
	<ul style="list-style-type: none"> Oil leak. 	<ul style="list-style-type: none"> Look for the leak and contact specialized staff.
	<ul style="list-style-type: none"> Helm mounted upside down. 	<ul style="list-style-type: none"> Mount the helm with the filling hole in up position.
Leaks from steering system fittings.	<ul style="list-style-type: none"> Bad tightening or low torque of the fittings. 	<ul style="list-style-type: none"> Tighten the fittings with a maximum torque of 20Nm (15 in.lbs).
	<ul style="list-style-type: none"> Lack of fitting sealant. <p>⚠ WARNING</p> <p>Never use teflon tape or adhesive tape on any fitting.</p>	<ul style="list-style-type: none"> Drain and disassemble the steering system. Remove the fittings and remove the oil from threads. Put the sealant on the fittings and tighten them, install the helm. <p>⚠ WARNING</p> <p>After this operation it is necessary to carry out another bleeding.</p>
Leaks from the tank plug.	<ul style="list-style-type: none"> Bad tightening of the plug. 	<ul style="list-style-type: none"> Tighten the plug.
	<ul style="list-style-type: none"> The vent plug on the additional helm is in the lower position. 	<ul style="list-style-type: none"> Replace the vent plug with the plug for the additional helm kit.
	<ul style="list-style-type: none"> Worn and damaged seal. 	<ul style="list-style-type: none"> Replace the plug.
	<ul style="list-style-type: none"> Too high oil level. 	<ul style="list-style-type: none"> Follow the procedure to maintain the suitable oil level (see paragraph "purging procedure").



6 DISMANTLING

6.1 Dismantling

When for any reason, the steering system is put out of service, it is necessary to follow some rules in order to respect the environment.

Sheaths, pipelines, plastic or non-metallic components must be disassembled and disposed of separately.

*The steering system **CONTAINS POLLUTING OILS**
which must be disposed of according to the rules in force in the country.*

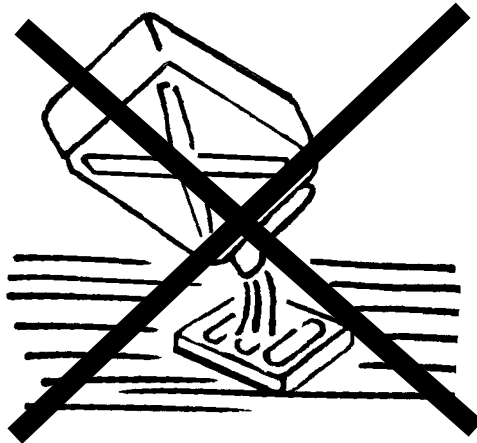

ULTRAFLEX S.p.A.

16015 Casella (Genova) Italia - Via Crose, 2